



*Specialists in Embedded RF Data Communications,
Monitoring and Control Systems*

Product Reference Guide.

POC-220 - POCSAG Encoder IC

and

POCSAG Evaluation Kit

using the

Radiometrix LMT1, BiM1T, TX1, TX1H & NiM2T

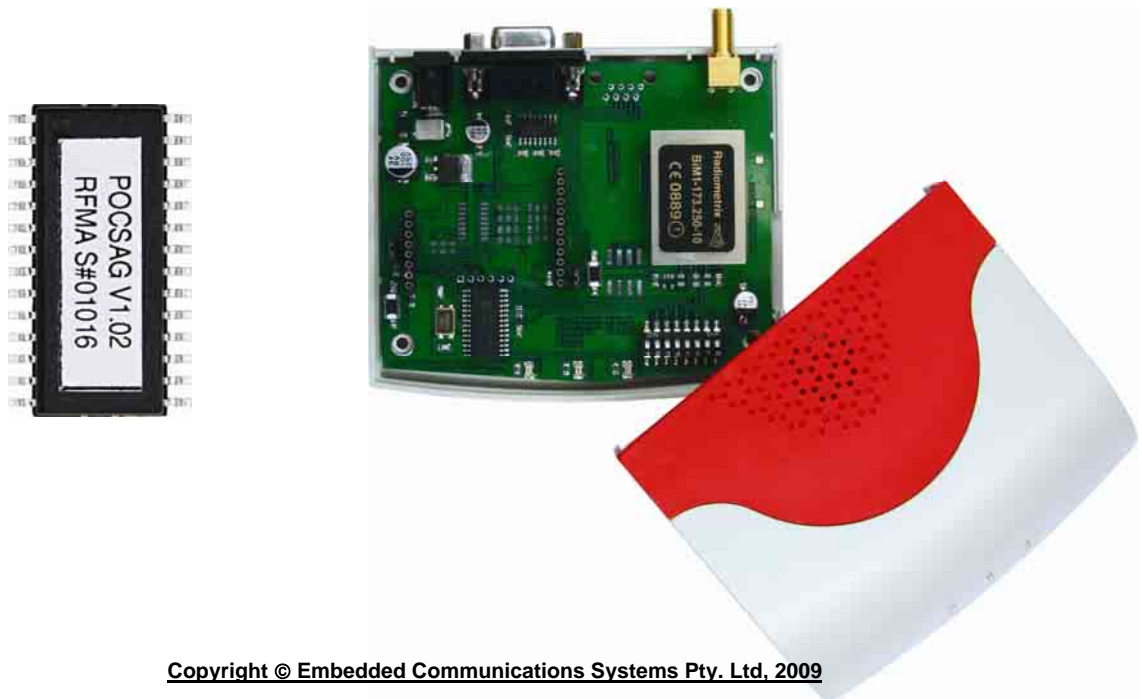

Copyright © Embedded Communications Systems Pty. Ltd, 2009

The moral right of the author has been asserted. All rights reserved.

No part of this publication may be reproduced, stored in a retrieval system or transmitted in any form or by any means without the prior permission, in writing, of Embedded Communications Systems Pty. Ltd., nor be otherwise circulated in any form of binding or cover other than in which it is published and without a similar condition, including this condition, being imposed on the subsequent purchaser or user.

Disclaimer

This reference is based on information that was available at the time of printing. Embedded Communications Systems Pty. Ltd. reserves the right to make changes to this Document at any time without notice and without obligation. Embedded Communications Systems Pty. Ltd. makes no representation or warranty, expressed, implied or statutory with respect to the information in this Document.

POCSAG Encoder

This POCSAG Encoder IC is a full featured IC for generating the POCSAG signaling patterns used for most modern day data pagers. A serial interface allows free form user generated pager messages to be sent. The internal POCSAG engine takes care of the preamble, synchronization and bit balancing used in the POCSAG signalling standard.

The POCSAG Encoder IC is designed to interface directly to a number of Radiometrix license free narrow band transmitter radio modules (or any RF module with +/-3khz deviation) such as the LMT1 multichannel transmitter, the BiM1T, the TX1 & TX1H and the NiM1T.

The POCSAG Encoder IC provides a fully configurable radio interface allowing it to interface to most radio modules. Initial chip configuration can be performed either by hardware jumper pins or serially via serial commands. Chip configuration is stored in internal EE memory and therefore only needs to be configured once.

Key Features

- Compatible with most modern 1200 baud commercial pagers
- Serial interface. 2400, 4800, 9600, 19200, 38400 & 57600 support
- Easy configuration by hardware jumpers or serial interface
- Configurable radio interface suits Radiometric BiM1T, TX1, TX1H, NiM1T
- Low power mode for battery powered application (via chip enable)
- Field upgradable via internal bootloader
- Available as an OEM chip solution for embedded applications
- Evaluation kit available with headers for user built expansion boards

Ordering Information

The POCSAG Encoder IC is a 28 pin IC. It is available in the following packages.

POC-220-I/SO 28 Pin SOIC Industrial Temp

POC-220-I/DP 28 Pin Skinny Plastic DIP Industrial Temp

Please enquire with regard to packages styles and temperature ranges.

POCSAG Encoder IC Electrical Specification

The POCSAG Encoder IC uses a Microchip PIC18LF2525 microcontroller. For all electrical specifications of the microcontroller please download the datasheet for the PIC18LF2525 from www.microchip.com.

The VDD operating voltage range of the POCSAG Encoder IC is from 2.0V to 5.5VDC. It is recommended that power supply ripple is kept at or below 30mV peak-to-peak.

The POCSAG Encoder IC is designed to operate with a 9.2160MHz 50ppm crystal. Currently the POCSAG data rate is fixed to 1200 baud.

Configuration Command Reference

The following commands are specific for setting the configuration of the IC in general. Use the sequence '+++' to enter the configurator. Note, all commands should be followed by a carriage return to initiate the command. It will also accept a normal carriage return + linefeed sequence.

- **'exit'**
Leave the configurator. Configurator will automatically time out after no activity when not in an active command state.
- **'reboot'**
What it says. A reboot essentially restarts the POCSAG encoder with the either the current EE settings or pin state settings.
- **'bootloader'**
Before using this command it is advisable to execute the **'list'** command to capture current configuration as it will be erased during the software upgrade.

Using a serial port terminal program like HyperTerminal enter '+++' (without quotes) to enter the configurator. Enter the command **'bootloader'** and when 'XMODEM NOW!' is shown after the device reboots, start an XMODEM transfer of the newly supplied software file to the device. After a couple of minutes it will have update the firmware and rebooted. The bootloader runs at a fixed 9600 baud.

Now the pre-bootload configuration can be restored to the unit by feeding the lines captured with the 'list' command back into the configurator or by manually entering them.

- **'baud [2400-57600]'**
Without parameters displays current baud rate, with a valid value from 2400 to 57600 it changes the baud rate after the next reboot or power cycle, unless overridden by the DIP switch setting.
- **'flow [none|hw]'**
Flow control setting for CTS signaling. Default is HW.
- **'signon [on|off]'**
Enable or disable the sign on text output message. The sign-on message is on by default. The sign-on message is useful for initial setup and testing, such that when power is first applied to the chip the sign-on message is sent out the serial port. In most cases the sign-on message can be disabled as it is of very little use after the initial development phase.
- **'serial' 'info' 'support' 'list' 'help'**
The command names describe their function.

POCSAG Command Reference

The following commands are specific for both configuring POCSAG specific settings and sending POCSAG messages. All POCSAG commands are preceded by a '#poc,'. POCSAG commands are accessed by sending the commands directly to the IC via the UART at the chosen baud rate.

- **#poc,[RIC],[FUNC BITS],[MODE],<"TEXT">**
Send a POCSAG message.
- **#poc,PTT,<norm,invert>**
Set the PTT level. Normal or invert.
- **#poc,DATA,<norm,invert>**
Set the Data Pin state. Normal or invert.
- **#poc,RATE,<512,1200,2400> (currently FIXED to 1200 in firmware V1.xx)**
Set the POCSAG data rate. Current 1200 baud is implemented only.
- **#poc,PRE,<576-9999>**
Set the POCSAG preamble cycles. Default is 580 and is the minimum required for POCSAG.
- **#poc,EELOAD**
Load POCSAG settings from internal EE.
- **#poc,EESAVE**
Save current POCSAG settings to internal EE.
- **#poc,EEFACT**
Revert POCSAG settings back to factory defaults.

POCSAG Message Information

The following details POCSAG specific information:

- **RIC**
Receiver Identity Code 1 to 2097151
- **FUNC BITS [0, 1, 2, 3]**
0==nominal numeric page
1==nominal tone page
2==nominal tone page
3==nominal alpha numeric page
- **MODE [T, N, A]**
T==Tone only page
N==numeric page (non valid numeric characters converted to a space)
A==Alpha numeric page

POCSAG Encoder Notes

- Pager must be programmed correctly for numeric and erase all messages to function.
- String parameter and last comma optional for tone page, use empty quotes "" for no string if used.
- String quotes around text only required if embedded space or comma etc. The best approach is to just use quotes always.
- Use of \nxx is allowed in strings to embed control characters. Except for \x00 which is not allowed.
- Use \" (slash quote) for a " (single quote) and \\ (slash slash) for a \ (single slash)
- Some pagers are unable to handle many of the control characters and give unreadable / corrupted output on their character displays.
- All successfully sent pager message respond with 'ok'
- For additional POCSAG operational information searching the internet will yield an abundance of literature.

POCSAG Command Examples

Numeric:

```
#poc,1234567,0,n,"[12345U]"
```

Tone Only:

```
#poc,1234567,0,t
```

```
#poc,1234567,1,t
```

```
#poc,1234567,2,t
```

```
#poc,1234567,3,t
```

Alpha Numeric:

```
#poc,1234567,3,a,"hello world"
```

```
|      |      |
```

```
hello world
```

```
#poc,1234567,3, A, "\"quoted\""\x2B\"'\slash\""
```

```
|      |      |      |      |
```

```
"quoted"+"\slash\"
```

Erase all messages (pager specific coding):

```
#poc,1234567,3,a,[0092][0]
```

Error Messages

All commands produce a response either status information or an error. Following are the two error message and their meanings:

- **ok**
The entered command was received and processed successfully.
- **error**
The entered command was not processed due to an error. Either the command is not a valid command or the supplied parameters are incorrect.

Why CTS and BUSY?

The POCSAG Encoder IC has two status output pins. They are used to indicate different internal statuses.

BUSY is an active high signal that indicates a POCSAG radio transmission is in progress. Where as the CTS line, an active high output at the chip, is used to indicate the serial receive buffer is full and not able to receive any more characters.

It is possible to queue transmit messages to the POCSAG Encoder IC, which are executed one at a time. If several messages are sent before the current message has been transmitted (which may be possible if running long preamble), then CTS is asserted at the 50% full mark of the serial receive queue which is 128 bytes long. In this case BUSY will be active while the transmissions are in progress.

How these two signals are used is dependant on the application. In some instances the BUSY signal would be more appropriate to control flow of commands into the unit and to determine transmit activity. However in a streaming application sending multiple POCSAG transmit commands monitoring CTS would provide the best solution.

While a POCSAG transmit command, when successfully completed, will reply with an OK, this OK could be delayed by many seconds if running with very long preamble. Thus several messages may be sent to the POCSAG Encoder IC before an OK is returned.

POCSAG Bootloader and Firmware

The POCSAG Encoder IC contains an internal bootloader suitable for updating the POCSAG firmware while in-circuit.

This manual relates to the following firmware version:

POCSAG Firmware:	V1.02
Bootloader Firmware:	V3.05

The default serial baud rate for the POCSAG Encoder IC is 1200.

The default bootloader baud rate for the IC is 9600.

Pin Usage Described

Interfacing to the POCSAG chip is simple with few connections being required.

Pin #	Pin Name	Direction	Description
1.	RESET	Input	Active low to reset the chip. 10K pull up to VCC required
2.	Reserved	Input	Reserved for future use. Tie to ground
3.	Reserved	Input	Reserved for future use
4.	Reserved	Input	Reserved for future use
5.	Reserved	Input	Reserved for future use
6.	Reserved	Input	Reserved for future use
7.	BUSY	Output	Active high. Indicates POCSAG send in operation
8.	GND	Power	Signal ground
9.	OSC1	Input	Oscillator 1. Use 9.2160MHz crystal. Decoupled with 22pf
10.	OSC2	Input	Oscillator 2. Use 9.2160MHz crystal. Decoupled with 22pf
11.	PTT	Output	Radio transmit enable – PTT
12.	PIN12	Output	MUST be connected to pin #14
13.	CTS	Output	Active low. Clear To Send for serial data buffer
14.	PIN14	Input	MUST be connected to pin #12
15.	RRXD	Input	This must be tied to ground
16.	RTXD	Output	Radio transmit data – RTXD. Connect to the radio data input.
17.	TXD	Output	TTL level serial data out
18.	RXD	Input	TTL level serial data in
19.	GND	Power	Signal ground
20.	VCC	Power	POCSAG chip power. +3.0VDC to +5VDC <30mV ripple
21.	B_TXD	Input	Radio data pin (RTXD) invert = 0, normal = 1.
22.	B_PTT	Input	Radio PTT pin (PTT) invert = 0, normal = 1.
23.	B_CE	Input	Active low. Chip Enable. High puts the chip into sleep
24.	B_DFLT	Input	Reset factory defaults. Write current DIP switch settings to EE
25.	B_RATE0	Input	00 = POCSAG uses current EE settings POCSAG Rate : 01 = 512, 10 = 1200, 11 = 2400
26.	B_RATE1	Input	
27.	B_BAUD0	Input	
28.	B_BAUD1	Input	Serial baud rate. 2400, 4800, 9600, 19200

Factory Defaults

Factory defaults for the POCSAG encoder chip are for driving a Radiometrix BiM1T module.

Serial:	9600
Transmit data:	Inverted
PTT:	Inverted
POCSAG Rate:	1200
Preamble:	580

Allowable Numeric Characters Codes

Displayed Character	4-bit Combination
0	0000
1	0001
2	0010
3	0011
4	0100
5	0101
6	0110
7	0111
8	1000
9	1001
Spare	1010
U (urgent)	1011
Space	1100
Hyphen	1101
]	1110
[1111

Allowable ASCII Character Codes

ISO 7-bit (ASCII)				b7	0	0	0	0	1	1	1	1
				b6	0	0	1	1	0	0	1	1
				b5	0	1	0	1	0	1	0	1
b4	b3	b2	b1		↓							
0	0	0	0	→	NUL	DLE	SP	0		P		p
0	0	0	1		SOH	DC	!	1	A	Q	a	q
0	0	1	0		STX	DC	"	2	B	R	b	r
0	0	1	1		ETX	DC	#	3	C	S	c	s
0	1	0	0		EOT	DC	\$	4	D	T	d	t
0	1	0	1		ENQ	NAK	%	5	E	U	e	u
0	1	1	0		ACK	SYN	&	6	F		f	v
0	1	1	1		BEL	ETB	'	7	G	W	g	w
1	0	0	0		BS	CAN	(8	H	X	h	x
1	0	0	1		HT	EM)	9	I	Y	i	y
1	0	1	0		LF	SUB	*	:	J	Z	j	z
1	0	1	1		VT	ESC	+	;	K		k	
1	1	0	0		FF	FS	,	<	L		l	
1	1	0	1		CR	GS	-	=	M		m	
1	1	1	0		SO	RS	.	>	N	^	n	
1	1	1	1		SI	US	/	?	O	_	o	DEL

220 POCSAG Encoder Pinout

MINIMUM INTERFACE REQUIREMENTS

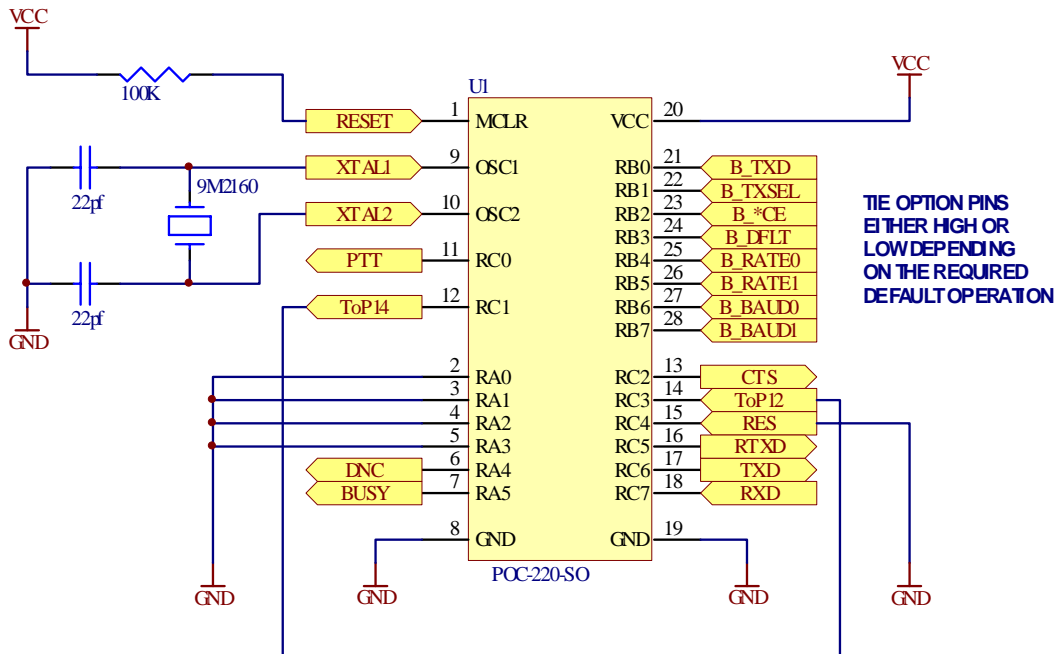

POCSAG CHIP PIN OUT

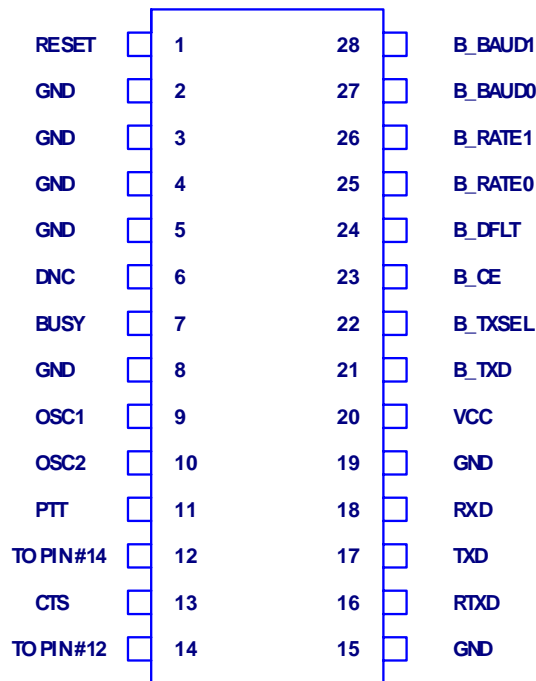

DNC - DO NOT CONNECT

220 POCSAG Evaluation Kit Schematic

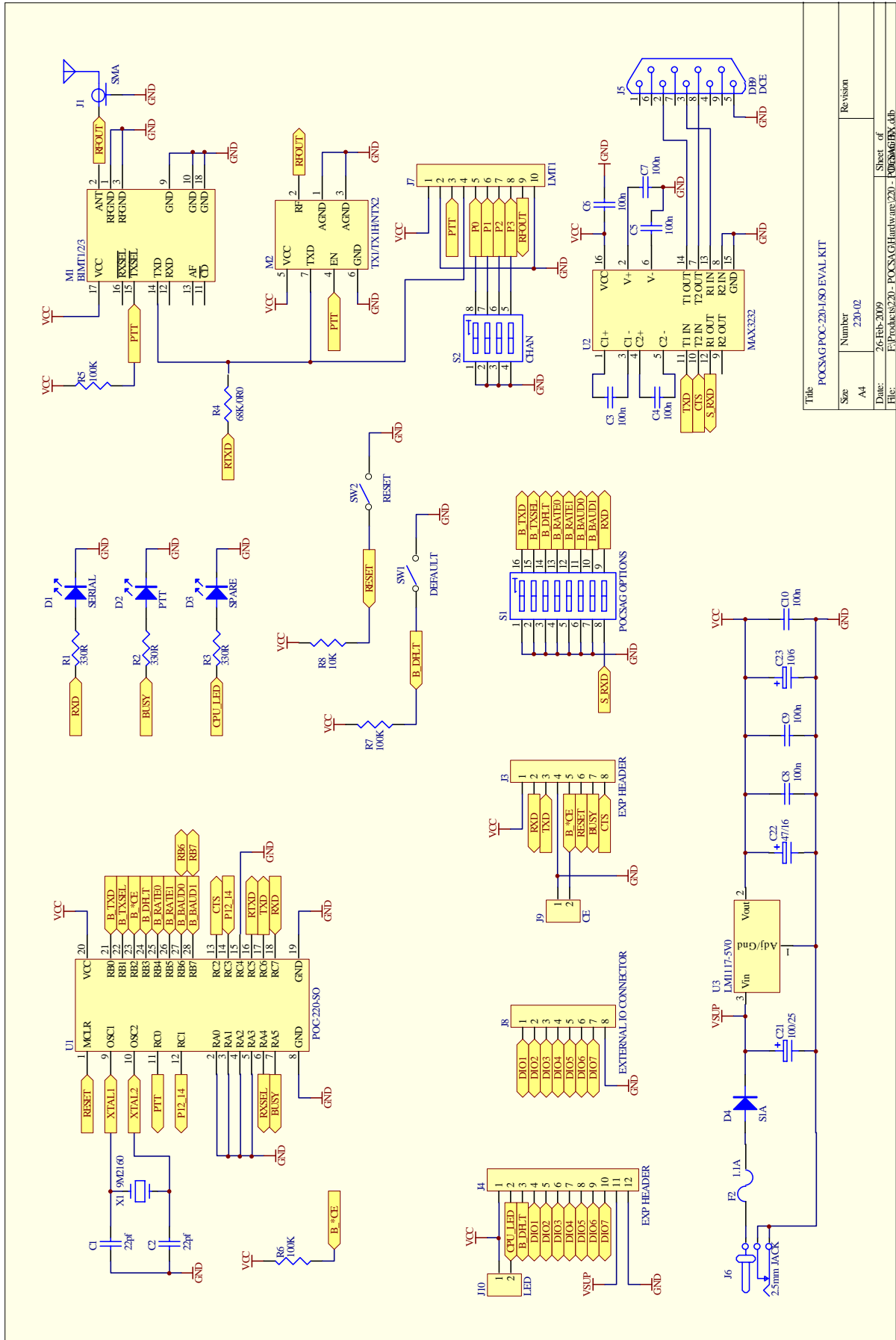

Title		POCSAG POC-220-ISO EVAL KIT	
Size	Number	Revision	
A4	231-02		
Date:	26-Feb-2009		Sheet of
File:	E:\Products\220 - POCSAG\Hardware\220 - POC220S0.BX.dtb		

POC-220 POCSAG Eval Kit DIP Switches

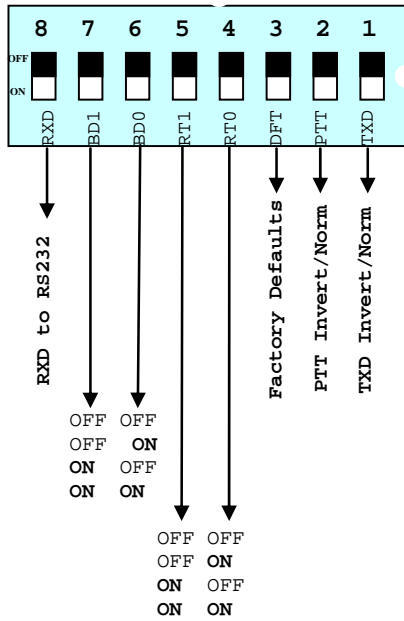

POCSAG EVAL KIT OPTIONS

Function

Serial 2400bps
 Serial 4800bps
 Serial 9600bps
 Serial 19200bps

POCSAG uses defaults from EE
 POCSAG rate 512 (Currently 1200)
 POCSAG rate 1200
 POCSAG rate 2400 (Currently 1200)

BIM Default:

TXD : Invert
 PTT : Invert
 DFT : OFF
 RATE : 1200
 BAUD : 2400

RXD : Enables/disabled serial receive data into POCSAG chip
 BD0 & BD1 : Set the serial interface baud rate
 RT0 & RT1 : Set the POCSAG data rate (fixed at 1200)
 PTT : Invert or normal PTT to radio module
 TXD : Invert or normal data to radio
 DFT : Load defaults from DIP switches or internal EE.