

NEW

Radiometrix

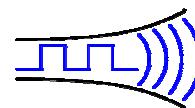

Issue 1, 09 June 2008

Harteran House, 231 Kenton Lane, Harrow, HA3 8RP, England

Tel: +44 (0) 20 8909 9595, Fax: +44 (0) 20 8909 2233

LMT1/LMR1

VHF Narrow Band FM Low Cost multi channel radio modules

The LMT1 transmitter and LMR1 receiver modules offer a multi channel, low power, and reliable VHF data link. This makes the LMT1/LMR1 pair ideally suited to those low power applications where existing wideband modules have insufficient range, or where low cost multi-channel operation is needed without compromising on RF specification or regulatory requirement.



Figure 1: LMT1 transmitter and LMR1 receiver

Features

- Conforms to EN 300 220-3 and EN 301 489-3
- High performance double superhet. PLL synthesizer with TCXO
- quasi-dc (peak sampling) data recovery circuit (for enhanced performance on unbalanced datastreams)
- Data rates up to 5 kbps for standard module
- Usable range over 1km
- Fully screened. Low profile
- Feature-rich interface (RSSI, analogue and digital baseband)
- Re-programmable via RS232 interface
- Low power requirements

Applications

- Handheld terminals
- EPOS equipment, barcode scanners
- Data loggers
- Industrial telemetry and telecommand
- In-building environmental monitoring and control
- High-end security and fire alarms
- DGPS systems
- Vehicle data up/download
- Heavy vehicle/machinery controls

Technical Summary

- Operating frequency: 173.200 - 173.325MHz (UK band)
150.825 - 152.450MHz (Australian Band)
- Other VHF frequencies available
- 4 UK allocation channels (32 maximum)
- Transmit power: +10dBm (10mW) nominal @ 3.1V (Adjustable 1 - 25mW)
+20dBm (100mW) nominal @ 4.1V (Adjustable 25 - 100mW)
- Supply range: 3.1 - 15V (@10mW) transmitter and receiver
- Current consumption: 34mA @ 10mW, 90mA @ 100mW (transmit) and 20mA (receive)
- Data bit rate: 5kbps max. (Standard module)
- Receiver sensitivity: -118dBm (for 12 dB SINAD)
- Serial configuration by inverted RS232 at 3V CMOS level

LMT1 VHF multi-channel transmitter

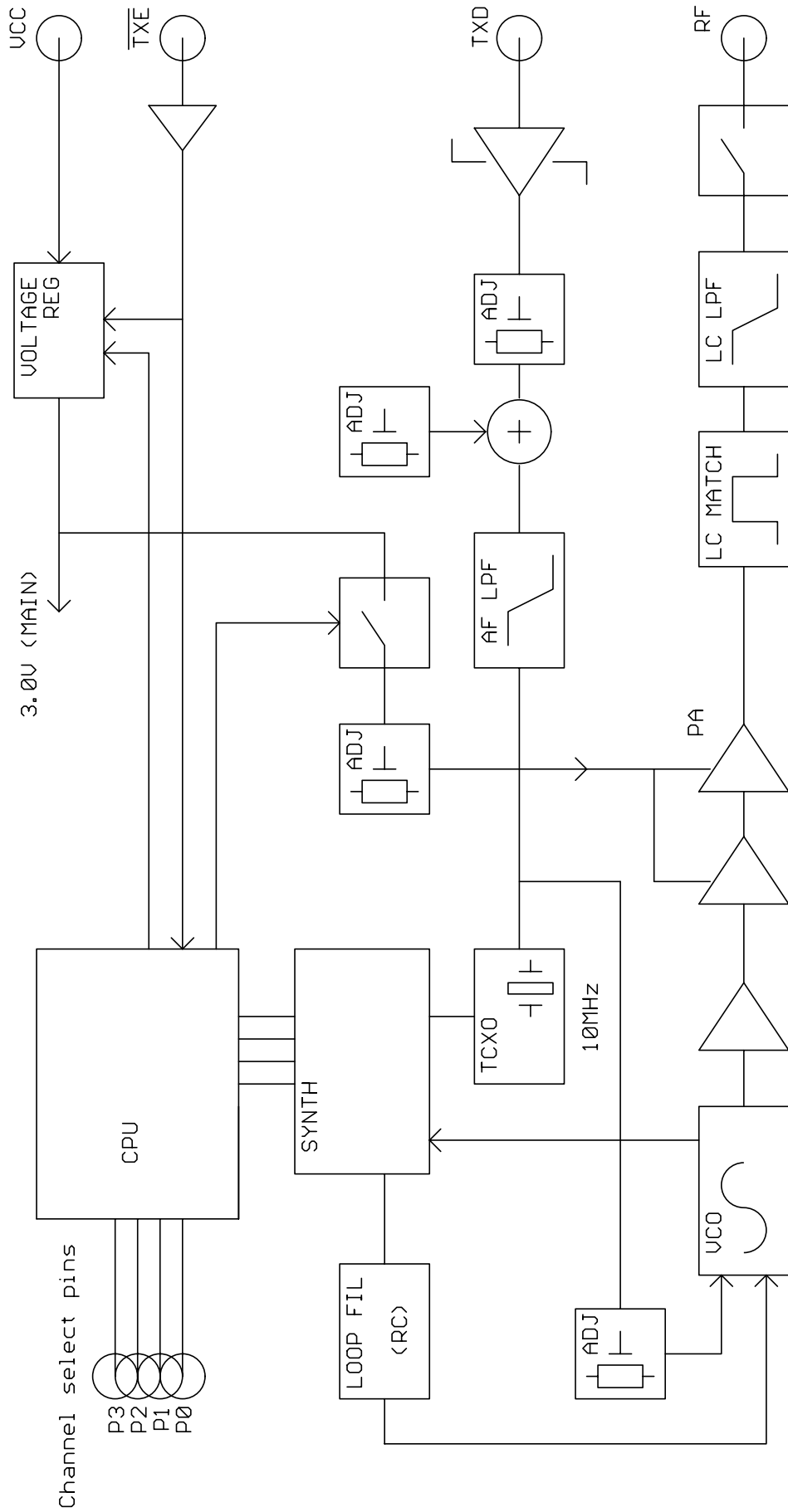

Figure 2: LMT1 block diagram

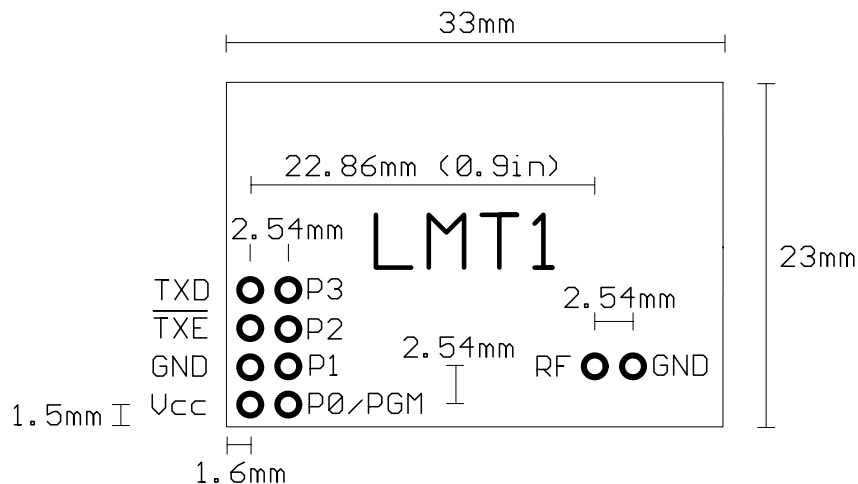

Figure 3: LMT1 footprint (top view)

Pin description - LMT1

Pin	Name	Function
1a	Vcc	3.1 – 15V power supply (10mW) 4.1V – 15V power supply (100mW)
2a	0V	Ground
3a	$\overline{\text{TXE}}$	Transmit Enable (active low)
4a	TXD	DC coupled input for 3V CMOS logic. $R_{in}=47k\Omega$
5a	No pin	Not present in LMT1
1b	P0/PGM	Parallel Channel select LSB Serial frequency programming / configuration ¹
2b	P1	Parallel Channel select
3b	P2	Parallel Channel select
4b	P3	Parallel Channel select MSB
5b	No pin	Not present in LMT1

Notes:

1. Serial programming is by an inverted, CMOS logic level, 2400 baud RS232 datastream applied to the P0 pin.
2. Channel select inputs have pullups (50k Ω) to 3v internal rail. Do not exceed 3V logic levels on this port.
3. Channel select inputs are active low
4. $\overline{\text{TXE}}$ has a 100k Ω pullup to Vcc
5. All pins are on an 0.1" grid
6. The pins 5a/b are not present, but are included in footprint for compatibility with other units in this family
7. In the 'off' state a PIN switch open circuits the RF output pin. There are no 'off' state spuri.
8. Unit will operate (with marginally reduced specifications and lower (6-8mW) output power) from a 3.0V rail. This must be well regulated and without noise or ripple, as in this state the unit's internal regulator no longer operates, and provides no supply rejection.
9. 100mW versions should not be run continuously from supply voltages > 9v

LMR1 VHF multichannel receiver

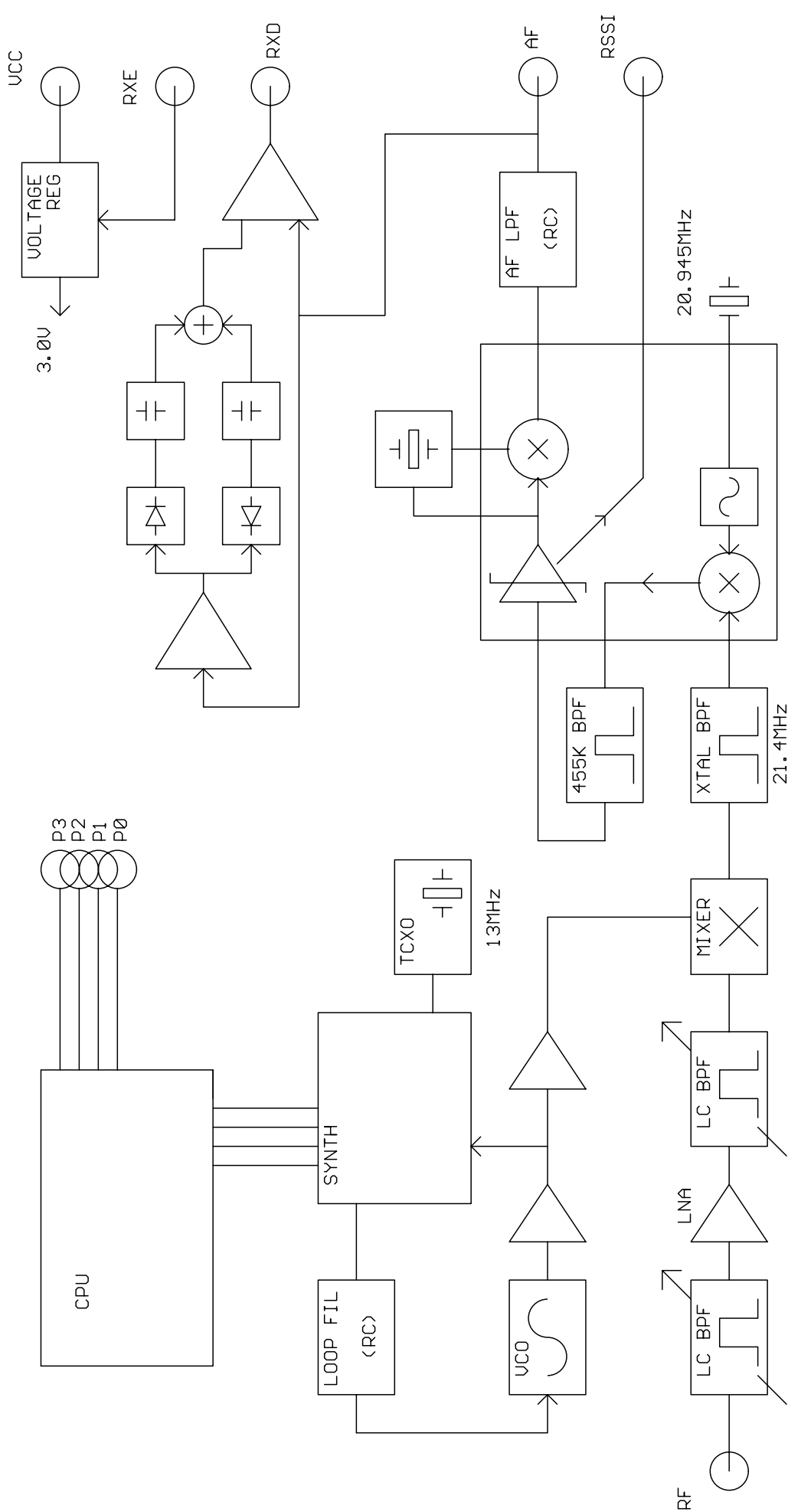

Figure 4: LMR1 block diagram

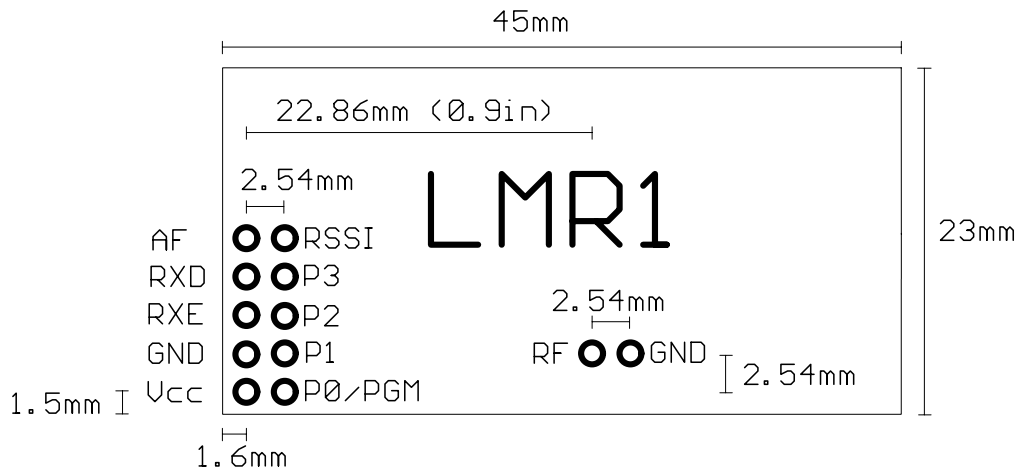

Figure 5: LMR1 footprint (top view)

Pin description - LMR1

Pin	Name	Function
1a	Vcc	3.1 – 15V power supply
2a	0V	Ground
3a	RXE	Receiver Enable (active high)
4a	RXD	Data out (open collector, no pullup)
5a	AF out	700mV p-p audio. DC coupled, approx 0.8v bias.
1b	P0/PGM	Parallel Channel select LSB Serial frequency programming / configuration ¹
2b	P1	Parallel Channel select
3b	P2	Parallel Channel select
4b	P3	Parallel Channel select MSB
5b	RSSI	DC level between 0.5v and 2.2v. 60dB dynamic range

NOTES:

1. Serial programming is by an inverted, cmos logic level, 2400 baud RS232 datastream applied to the P0 pin.
2. Channel select inputs have pullups (50kΩ) to 3v internal rail. Do not exceed 3v logic levels on this port.
3. Channel select inputs are active low
4. All pins are on an 0.1" grid
5. Data recovery circuit used for RXD is not a simple 'average and compare' type. It is a peak sampling quasi-DC coupled design, allowing a greater than usual flexibility in data format.
6. Unit will operate (with marginally reduced specifications) from a 3.0v rail. This must be well regulated and without noise or ripple, as in this state the unit's internal regulator no longer operates, and provides no supply rejection.

Serial interface commands

2400 baud RS232. 8 bit data, no parity, 1 start bit, 1 or 2 stop bits.

Serial data is sent to the unit on one of the parallel channel select pins (P0). It is very important that the unit does not 'decode' switch bounce in ordinary operation as a command string, or spurious re-writing of the e2prom will result. For this reason the user must send the 16 character string ENABLESERIALMODE (followed by a carriage return) to activate the serial command mode before sending any of the command strings listed below. Command mode is disabled on power down, or on reception of a # character. To successfully program the unit, it must be enabled (RXE high (rx) or TXE low (tx)).

GOCHAN aa	Serially select channel aa, where aa is ch0 to ch31
LOAD aa nnnnn	Set value of N register for channel aa, where aa is Channels 0 to 31
SETPAR	Channel selected by 4 bit parallel inputs (ch0 to ch15 only)
SETSER	Channel selected by most recent GOCHAN operation
RVALUE rrrr	Set value for R register
SINGLE nnnnn	Set value of N for single channel operation. N value NOT stored in EEPROM
<cr>	Process entry
/	Clear all buffers
#	Disable command mode

aa = a two digit channel number from 00 to 31

nnnnn = synthesizer N register value (up to 65535)

rrrr = synthesizer R register value (up to 16383)

For LMT1 Transmitter:

$$R = \frac{f_{Xtal}}{f_{channelspacing}} = \frac{10MHz}{25kHz}, \text{ So } R=400$$

$$N_{TX} = \frac{f_{RF}}{f_{Channelspacing}} = \frac{173.250MHz}{25kHz} = 6930$$

For LMR1 Receiver:

$$R = \frac{f_{Xtal}}{f_{channelspacing}} = \frac{13MHz}{25kHz}, \text{ So } R=520$$

$$N_{RX} = \frac{f_{RF} - 21.4MHz}{f_{Channelspacing}} = \frac{173.250MHz - 21.4}{25kHz} = 6074$$

- Notes:**
1. A pause of at least 50ms must be allowed between command strings (EEPROM programming time).
 2. SINGLE mode does not store the N value in EEPROM. Therefore the unit is inoperative after a power down until either another valid SINGLE command is received, or mode is changed by a GOCHAN, SETPAR or SETSER command. SINGLE mode is intended for frequency agile applications.
 3. For UK version (173.200 - 173.325MHz band) the following channel assignment is supplied:

CH0: 173.250MHz

CH1: 173.275MHz

CH2: 173.300MHz

CH3: 173.325MHz

CH4 - CH7: 173.225MHz (only used for alarm applications)

CH8 - CH31: 173.325MHz

Condensed specifications

Frequency Any frequency in the 173MHz and 151MHz bands
In UK band, only 173.250, 173.275, 173.300 and 173.325 MHz are used as standard

Other custom variants from 130 - 180MHz on any 2MHz band

Frequency stability ±1.5kHz
Channel spacing 25kHz (12.5kHz by special order)
Number of channels 16 channels controlled by parallel port
or 32 via serial RS232 interface

Operating temperature -20 °C to +70 °C (Storage -30 °C to +70 °C)
Spurious radiations Compliant with ETSI EN 300 220-3 and EN 301 489-3

Transmitter	
Output power	+10dBm (10mW) ±1dB nominal (factory adjustable 1 - 25mW) and +20dBm (100mW) ±1dB nominal (factory adjustable 25 - 100mW)
Peak deviation	±3kHz (±1.5kHz @ 12.5kHz channel spacing)
TX on switching time	30ms from TXE transition
Modulation type	FSK (F3D)
TX modulation bandwidth	DC – 5kHz (3V CMOS compatible)
Adjacent channel TX power	<-37dBm
TX spurious	<-40dBm (no RF output in Standby)
Supply	
Voltage	3.1V – 15V (10 – 25mW) 4.1V – 15V (25 – 100mW);
Current	34mA nominal transmit (@10mW) 90mA nominal transmit (@100mW) <8µA standby (TXE high or floating)
Inputs	data (CMOS/TTL compatible)
Size	33 x 23 x 9mm
Interface	<i>User</i> 10 (8) pin 0.1" pitch dual row (5+5) header
	<i>RF</i> 2pin 0.1" pitch
Recommended PCB hole size	1.2mm
Receiver	
Sensitivity	-118dBm for 12dB SINAD
S/N ratio	35dB (min), 40dB (typ) on AF output
AF bandwidth (-3dB)	4kHz
image	<-60db
Othr spurious	<-70dbm
Blocking	Better than 84dB
Adjacent channel	<-60dB
LO re-radiation	-70dBm
Supply	
<i>Voltage</i>	3.1V – 15V
<i>Current</i>	20mA receive
	<1µA standby (RXE low)
Outputs	RSSI, audio, data (quasi DC data recovery circuit)
Size	46 x 23 x 9 mm
Interface	<i>User</i> 10 pin 0.1" pitch dual row (5+5) header
	<i>RF</i> 2pin 0.1" pitch
Recommended PCB hole size	1.2mm

RX Received Signal Strength Indicator (RSSI)

The LMR1 has wide range RSSI that measures the strength of an incoming signal over a range of 60dB or more. This allows assessment of link quality and available margin and is useful when performing range tests.

The output on pin 5b of the module has a standing DC bias of up to 0.5V with no signal, rising to 2.5V at maximum indication (RF input levels of -40dBm and above). $\Delta V_{min-max}$ is typically 2V and is largely independent of standing bias variations. Output impedance is 40k Ω . Pin 5b can drive a 100 μ A meter directly, for simple monitoring.

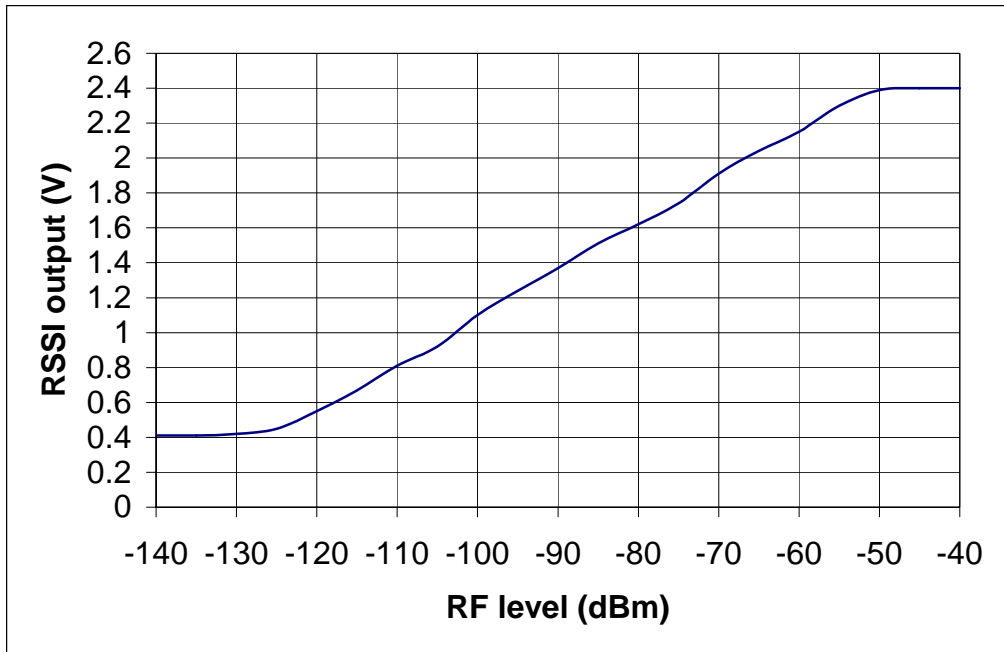

Figure 6: typical RSSI level with respect to received RF level at LMR1 antenna pin

Antenna requirements

Three types of integral antenna are recommended and approved for use with the module:

- A) **Whip** This is a wire, rod ,PCB track or combination connected directly to RF pin of the module. Optimum total length is 410mm (1/4 wave @ 173MHz). Keep the open circuit (hot) end well away from metal components to prevent serious de-tuning. Whips are ground plane sensitive and will benefit from internal 1/4 wave earthed radial(s) if the product is small and plastic cased
- B) **Helical** Wire coil, connected directly to RF pin, open circuit at other end. This antenna is very efficient given it's small size (20mm x 4mm dia.). The helical is a high Q antenna, trim the wire length or expand the coil for optimum results. The helical de-tunes badly with proximity to other conductive objects.
- C) **Loop** A loop of PCB track tuned by a fixed or variable capacitor to ground at the 'hot' end and fed from RF pin at a point 20% from the ground end. Loops have high immunity to proximity de-tuning.

	A	B	C
	<i>whip</i>	<i>helical</i>	<i>loop</i>
Ultimate performance	***	**	*
Easy of design set-up	***	**	*
Size	*	***	**
Immunity proximity effects	*	**	***

The antenna choice and position directly controls the system range. Keep it clear of other metal in the system, particularly the 'hot' end. The best position by far, is sticking out the top of the product. This is often not desirable for practical/ergonomic reasons thus a compromise may need to be reached. If an internal antenna must be used, try to keep it away from other metal components, particularly large ones like transformers, batteries and PCB tracks/earth plane. The space around the antenna is as important as the antenna itself.

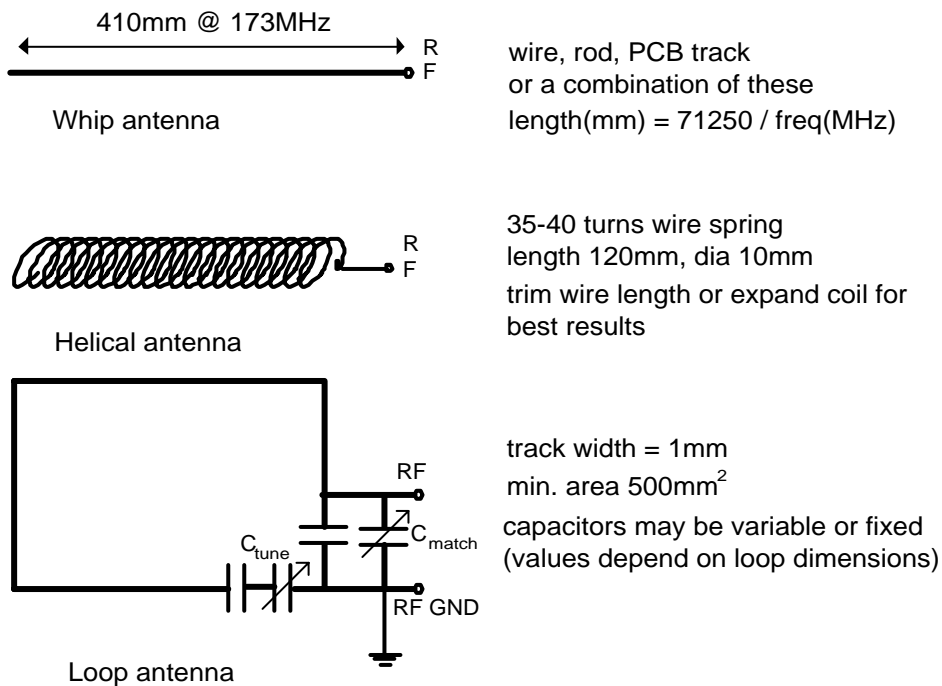

Figure 7: Antenna types

Ordering Information:

Part No.	Description	Frequency band (MHz)	RF power (mW)	Channel spacing (kHz)	Data rate kbps
LMT1-173-5	Transmitter	173.225 - 173.325	10	25	5
LMR1-173-5	Receiver	173.225 - 173.325		25	5
LMT1-151-5	Transmitter	150.825 - 152.450	100	25	5
LMR1-151-5	Receiver	150.825 - 152.450		25	5
LMT1-173-5-12k5	Transmitter	173.225 - 173.325	10	12.5	5
LMR1-173-5-12k5	Receiver	173.225 - 173.325		12.5	5
LMT1-151-5-12k5	Transmitter	150.825 - 152.450	100	12.5	5
LMR1-151-5-12k5	Receiver	150.825 - 152.450		12.5	5
LMT1-173-10	Transmitter	173.225 - 173.325	10	25	10
LMR1-173-10	Receiver	173.225 - 173.325		25	10
LMT1-xxx-5	Where xxx is any 2MHz band from 130MHz to-180MHz		10/100	25	5
LMR1-xxx-5				25	5

Radiometrix Ltd
Hartcran House
231 Kenton Lane
Harrow, Middlesex
HA3 8RP
ENGLAND
Tel: +44 (0) 20 8909 9595
Fax: +44 (0) 20 8909 2233
sales@radiometrix.com
www.radiometrix.com

Copyright notice

This product data sheet is the original work and copyrighted property of Radiometrix Ltd. Reproduction in whole or in part must give clear acknowledgement to the copyright owner.

Limitation of liability

The information furnished by Radiometrix Ltd is believed to be accurate and reliable. Radiometrix Ltd reserves the right to make changes or improvements in the design, specification or manufacture of its subassembly products without notice. Radiometrix Ltd does not assume any liability arising from the application or use of any product or circuit described herein, nor for any infringements of patents or other rights of third parties which may result from the use of its products. This data sheet neither states nor implies warranty of any kind, including fitness for any particular application. These radio devices may be subject to radio interference and may not function as intended if interference is present. We do NOT recommend their use for life critical applications. The Intrastat commodity code for all our modules is: 8542 6000.

R&TTE Directive

After 7 April 2001 the manufacturer can only place finished product on the market under the provisions of the R&TTE Directive. Equipment within the scope of the R&TTE Directive may demonstrate compliance to the essential requirements specified in Article 3 of the Directive, as appropriate to the particular equipment. Further details are available on The Office of Communications (Ofcom) web site:

<http://www.ofcom.org.uk/radiocomms/ifi/>

Information Requests
Ofcom
Riverside House
2a Southwark Bridge Road
London SE1 9HA
Tel: +44 (0)845 456 3000 or 020 7981 3040
Fax: +44 (0)20 7783 4033
information.requests@ofcom.org.uk

European Radiocommunications Office (ERO)
Peblingehus
Nansensgade 19
DK 1366 Copenhagen
Tel. +45 33896300
Fax +45 33896330
ero@ero.dk
www.ero.dk