

**NEW**

# Radiometrix

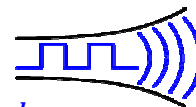

Hartcran House, 231 Kenton Lane, Harrow, HA3 8RP, England

Issue 1, 28 April 2005 Tel: +44 (0) 20 8909 9595, Fax: +44 (0) 20 8909 2233

**RPM1**

## VHF Radio Packet Modem

*The VHF Radio Packet Modem (RPM1) is a low cost intelligent radio packet modem that enables a two way radio network/link to be simply implemented between a number of digital devices. The RPM1 uses addressable data packets with error checking, packet acknowledgements and retransmissions to achieve a reliable transparent wireless data link. Built for ease of use and rapid installation, the serial interface ensures direct connection to microprocessors or to RS232 port via RS232 driver while remote configuration enables post installation setup of the modem.*

### Features

- ◆ Addressable point-to-point
- ◆ Point-to-Multipoint and broadcast modes
- ◆ Inverted RS232 Interface at 5V or 3.3VCMOS level
- ◆ DTE speed 600-115200bps
- ◆ Overall throughput: 3.7kbps with ACK  
5.3kbps without ACK
- ◆ Single 5V or 3.3V (10mW max) supply
- ◆ Flow control – Hardware (CTS), None
- ◆ Usable range over 1km
- ◆ Built-in command line configuration
- ◆ Built-in RF link diagnostics
- ◆ Remote over-air unit configuration
- ◆ Low operating current, Auto standby mode
- ◆ Conforms to European ETSI EN 300 220-3 and EN 301 489-3 (at 10mW)
- ◆ Conforms to Australian/New Zealand AS/NZS 4268:2003 (at 100mW)
- ◆ Dimensions: 39mm X 23mm X 15mm
- ◆ Available as RPM1T transmitter and RPM1R receiver for one way communication



**Figure 1: RPM1-173.250-3**

### Applications

- ◆ GPS (NMEA) position reporting
- ◆ Telemetry and telecontrol
- ◆ EPOS equipment, barcode scanners, belt clip printers, stock control, job allocation
- ◆ Remote data acquisition system, data loggers
- ◆ In-building, environmental monitoring and control systems
- ◆ High-end security and alarm signalling
- ◆ Automated Monitoring and Control Systems
- ◆ Fleet management, vehicle data acquisition

## INTRODUCTION

The *RPM1* is a self-contained Radio Packet Modem module that requires only a simple antenna, 5V supply and a serial I/O port on a host microcontroller or PC.

The module provides all the RF circuits and processor intensive low level packet formatting and packet recovery functions required to inter-connect any number of devices with serial port in a radio network.

A continuous stream of serial data downloaded by a Host microcontroller into the *RPM1* serial receive buffer is transmitted by the *RPM1*'s transceiver and will "appear" in the serial buffer of the addressed *RPM1* within radio range.

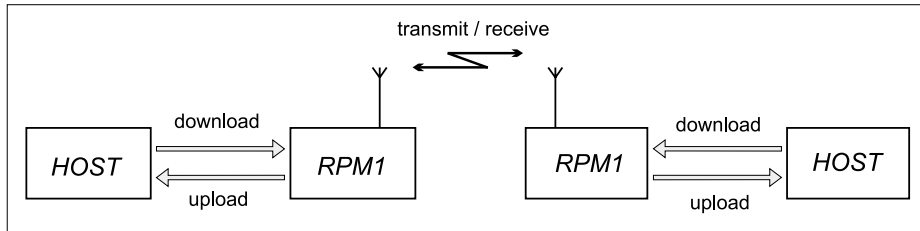
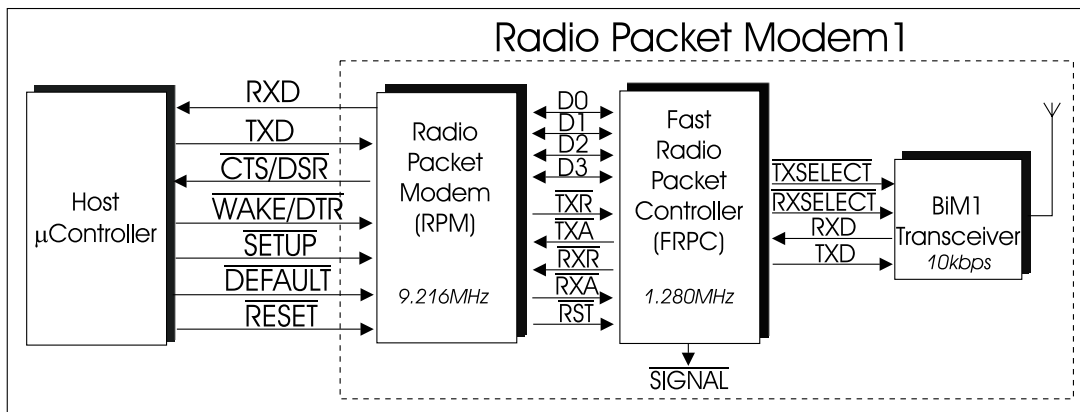

**Figure 2: Point to point wireless link with *RPM1* + Host microcontroller**

## 1. FUNCTIONAL DESCRIPTION

The *RPM1* is a connection oriented modem module for sending and receiving serial data via an RF communications link.

The *RPM1* handles all necessary protocol related functions of validation and retries to ensure error free and uninterrupted data is sent over the communications link. All data transfers between a pair of *RPMS* are fully acknowledged, thus preventing the loss of data. Bit coding and checksums are used on the data packets to ensure the validity of the received data at the remote end.



**Figure 3: *RPM1* block diagram**

## 1.1 OPERATING STATES

The RADIO PACKET MODEM has three normal operating states:

- *SHUTDOWN*
- *STANDBY*
- *CONNECTED*

### **SHUTDOWN**

The *SHUTDOWN* state is entered by asserting the  $\overline{\text{WAKE/DTR}}$  input pin high (Vcc). It effectively forces the RPM1 into a suspended state. Communications cannot be made with the RPM1 in this state.  $\overline{\text{WAKE/DTR}}$  pin should be pulled Low by host or connected to 0V to Enable the RPM1.

### **STANDBY**

Immediately after power up and during normal operation, the RPM1 will automatically enter standby mode where it is waiting for a connection request from a remote RPM1 module.

While in this mode a remote connection request can be received which will place the RPM1 into a connected state allowing it to then start receiving data from the remote unit. The connected host device can also send data to the RPM1 via the serial interface which will force the module to send a connection request to the remote RPM1 module, thus effectively setting up a logical connection between two units and allowing data to be transferred.

### **CONNECTED**

On receipt of a connection request from a remote unit, the RPM1 immediately enters a connected state. This effectively allows the RPM1 modems to start sending and receiving data.

In-coming data is sent to the host via the serial port in the same form as it was given to the remote RPM1 module.

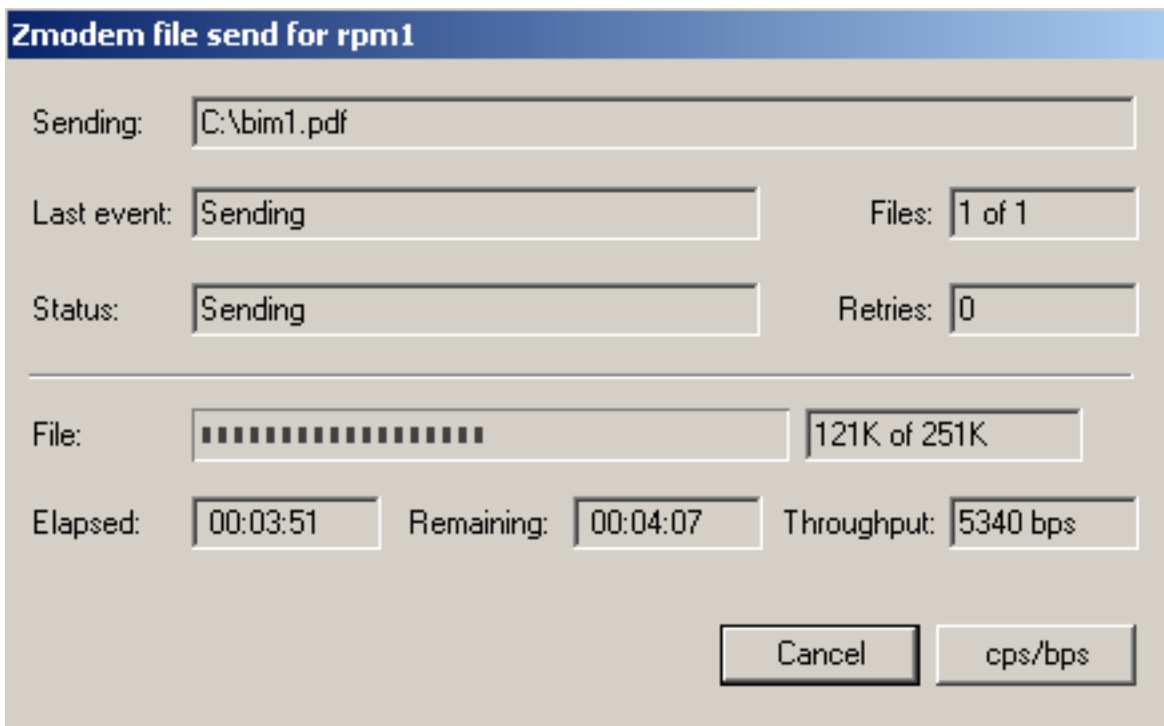

**Figure 4: RPM1 transmitting data at 5.3kbps during ZMODEM file transfer to a remote RPM1**

## 2 The Host Interface

### 2.1 SIGNALS

The connection to the RPM is a full duplex serial interface supporting baud rates from 600bps to 115200bps. Additional control signals are provided to assist in flow control, configuration and power saving in the RPM1.

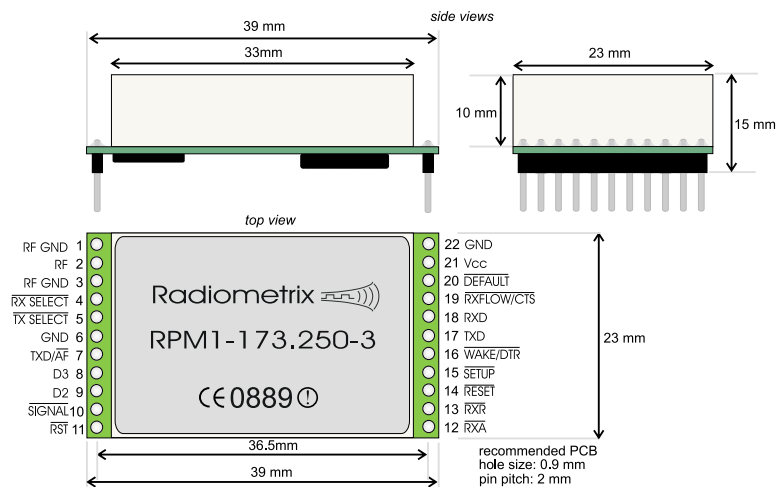

Figure 5: Physical dimensions and pinouts

| Pin name                      | Pin   | Pin Function                           | In/Out          | Description  |
|-------------------------------|-------|--|-----------------|--|
| RF GND                        | 1, 3  | RF signal ground                       |                 | BNC casing/coax braid connection   |
| RF                            | 2     | RF signal                              | Input or Output | Antenna pin/coax core connection   |
| $\overline{\text{RXSELCT}}$   | 4     | Receiver Select                        | Input or Output | Internal RF Receiver Enable to BiM1 or RF Receiver Active Indicator          |
| $\overline{\text{TX SELECT}}$ | 5     | Transmitter Select                     | Input or Output | Internal RF Transmitter Enable to BiM1 or RF Transmitter Active Indicator    |
| $\overline{\text{TXD/AF}}$    | 7     | Transmitted Data or demodulated signal | Input or Output | Transmitted Packetised Data to BiM1<br>Analogue Demodulated signal from BiM1 |
| D3                            | 8     | FRPC Data line                         | NC              | Internal data line between RPM and FRPC                                      |
| D2                            | 9     | FRPC Data line                         | NC              | Internal data line between RPM and FRPC                                      |
| SIGNAL                        | 10    | Preamble Detect                        | Output          | Valid preamble indicator   |
| $\overline{\text{RST}}$       | 11    | FRPC reset                             | NC              | Resets FRPC which also isolates BiM1   |
| $\overline{\text{RXA}}$       | 12    | Receive Acknowledge                    | NC              | RPM to FRPC download Request Acknowledge                                     |
| $\overline{\text{RXR}}$       | 13    | Receive Request                        | Output          | Valid Data packet indicator  |
| $\overline{\text{RESET}}$     | 14    | Reset                                  | Input           | Hardware reset of the RPM1   |
| SETUP                         | 15    | Enter Setup                            | Input           | Enter RPM1 configurator after a RESET  |
| WAKE/DTR                      | 16    | Wake or Shutdown                       | Input           | Wakes RPM1 when low, shuts down when high                                    |
| TXD                           | 17    | Serial transmitted data                | Input           | Host (DTE) to RPM1 serial transmit data                                      |
| RXD                           | 18    | Serial Received data                   | Output          | RPM1 to host (DTE) serial received data                                      |
| CTS                           | 19    | Clear To Send                          | Output          | Hardware flow control of data from host (DTE)                                |
| DEFAULT                       | 20    | Force 9600bps                          | Input           | Force the RPM1 serial interface to 9600bps                                   |
| VCC                           | 21    | Vcc Supply                             | Input           | +5VDC or +3.3VDC   |
| GND                           | 6, 22 | Ground                                 | -               | Supply Ground internally connected to RF GND                                 |

**Notes:**

1. RXD/TXD lines are true data
2. Active low SETUP, DEFAULT inputs require external 10k $\Omega$  pull-up to VCC.
3. Logic levels are 5V CMOS unless 3.3V variant is used.
4. WAKE pin should be pulled to ground if DTE cannot provide DTR signal
5. TXSELECT, RXSELECT, SIGNAL, RXR, CTS can be connected to LEDs via 1k $\Omega$  series resistors

### 2.2 RADIO PACKET MODEM RESET

#### RESET

The Reset signal is internally pulled up to Vcc via a 10k $\Omega$  resistor. A reset aborts any transfers in progress and restarts the RPM1.

#### HOST DRIVEN RESET

Minimum low time: 1.0  $\mu$ s, after reset is released (returned high). The host should allow a delay 1ms after reset for the RPM1 to initialise itself.

### **2.3 HOST TO RADIO PACKET MODE DATA TRANSFER**

Data is transferred between the RPM1 and the HOST using an asynchronous serial protocol. The default protocol settings are 8 data bits, no parity and 1 stop bit (8n1). The baud rate setting for the serial interface is user settable from 600bps to 115200bps.

#### ***TXD***

Data from the connected host (DTE) is received by the RPM1 through *TXD* pin.

#### ***CTS***

A single handshake line, *CTS*, controls the flow of data into the RPM1. The serial receive buffer of the RPM1 is 96 bytes deep. The *CTS* will be asserted High (VCC) by the RPM1 when the receive buffer hits approximately 66% full. It is advisable to limit the number of characters sent to the RPM1 after the *CTS* control line is asserted. This will help to reduce the possibility of lost data due to internal buffer overruns in the RPM1. The RPM1 will clear the *CTS* when the internal serial receive buffer falls below 33% full.

#### ***RXD***

Upon the RPM1 receiving data from a remote unit, the received data is sent to the connected host (DTE) device through the *RXD* pin.

### **2.4 ENTERING RADIO PACKET MODEM CONFIGURATOR**

Configuring the RPM1 is accomplished by using a built-in command line configurator. The configurator is entered by asserting the *SETUP* input of the RPM1 while resetting the RPM1.

#### ***SETUP***

Holding *SETUP* low during a reset cycle will force the modem into the configurator. The state of this input is checked while the RPM1 starts up from either power on or reset.

#### ***HOST DRIVEN SETUP***

The Setup pin may either be driven by the host (recommended) to enable host controlled configuration of the RPM1 or pulled up to VCC via a suitable pull-up resistor (10k $\Omega$ ).

### **2.5 FORCING DEFAULT SERIAL BAUD RATE**

Asserting this pin low forces the RPM1 to start-up with a default baud rate of 9600bps, 8 data bits, one stop and no parity.

#### ***DEFAULT***

During a *RESET* the *HOST* must hold *DEFAULT* low to force the RPM1 serial interface to default to 9600bps. This is ideal if the serial baud rate has been forgotten or incorrectly set.

#### ***HOST DRIVEN DEFAULT***

The *DEFAULT* pin may either be driven by the host (recommended) or pulled up to VCC via a suitable pull-up resistor (10k $\Omega$ ).

### **2.6 FORCING RADIO PACKET MODEM INTO SLEEP MODE**

Asserting the *WAKE* input high forces the modem into a low power sleep mode. This effectively shuts down the RPM1 and prevents it from sending or receiving any data. It is a method for conserving power when the modem is not required.

#### ***WAKE / DTR***

During normal operation *WAKE* pin can be pulled high to force the RPM1 to shutdown into low power sleep mode.

#### ***HOST DRIVEN WAKE***

The *WAKE* pin may either be driven by the host (recommended) or pulled Low to 0V.

## **TECHNICAL SPECIFICATION**

### **General**

#### **Operating Voltage**

5VDC or 3.3VDC

#### **Operating Current**

ACKMODE ON (100mW)

Transmitting

Average 62mA (Data streaming)

Receiving

Average 27mA (Data streaming)

ACKMODE ON (10mW)

Transmitting

Average 32mA (Data streaming)

Receiving

Average 18mA (Data streaming)

ACKMODE OFF (100mW)

Transmitting

Average 86mA (Data streaming)

Receiving

Average 12mA (Data streaming)

ACKMODE OFF (10mW)

Transmitting

Average 42mA (Data streaming)

Receiving

Average 12mA (Data streaming)

Auto-Standby

7mA (Waiting for Connection)

Power-down

1.2mA or 400µA<sup>3</sup>

#### **Standard Operating frequency**

151.300MHz (100mW)

173.225MHz or 173.250MHz (10mW)

Other custom frequencies between 120MHz-180MHz  
25kHz

#### **Channel spacing**

#### **Operating Temperature**

-10°C to +60°C

#### **Configuring options**

Built-in command line configurator

#### **Interface**

Serial Interface

Inverted RS232 at 5V or 3.3V CMOS level

Serial Protocol

8 data/1 stop/no parity

Serial Signals

RXD, TXD, CTS, WAKE

Power down Control

Via WAKE/DTR signal

Serial Handshaking

Selectable as CTS signal or none

DTE Interface Speed

600/1200/2400/4800/9600/19200/38400/57600/115200 bps

Air Interface Speed

10kbps

Overall throughput – Acknowledged

3.7kbps (max)

1.2kbps (slots)

0.6kbps (slotsw)

–

5.3kbps (max)

Unacknowledged<sup>4</sup>

1.2kbps (slots)

0.6kbps (slotsw)

#### **Receiver**

Sensitivity

-115dBm for 1ppm BER

LO leakage (conducted)

-70dBm

#### **Transmitter**

Output Power

+20dBm (100mW) ±1dB (5V variant only)

+10dBm (10mW)

Spurious Emissions

AS/NZS 4268:2003 limits (100mW variant)

EN 300 220-3 limits (10mW variant)

#### **Note:**

1. *RPM1 uses BiM1 (10kbps VHF Narrow Band FM) transceiver for its RF interface. Please refer to BiM1 data sheet for further details on the RF specification.*
2. *BiM1 (100mW/10mW) consumes 80mA/30mA on transmit and 8mA on receive*
3. *RPM1 Issue 1 maintains compatibility with the SHDN OFF feature in SPM2  
RPM1 Issue 2 will shut the 1.280MHz oscillator down when WAKE pin is pulled High to reduce power down current. SHDN should be left as ON and WAKE pin should be pulled Low to Enable RPM1.*
4. *RPM1T transmitter and RPM1R receiver can only be used with ACKMODE set to OFF*

### **3.0 RADIO PACKET MODEM CONFIGURATION**

#### **3.1 ENTERING THE CONFIGURATOR**

The RPM1 is configured by entering the built-in software configurator. Current argument can be displayed by entering parameter / command without argument

#### **3.2 USER CONFIGURABLE PARAMETERS**

|                |  |
|----------------|--|
| <b>CONFIG</b>  | <b>Display a list of the current RPM1 configuration.</b>   |
| Valid range    | This will also set <i>FLOW</i> control to <b>none</b> to enable simple 3 wire serial communication<br>None   |
| <b>DEFAULT</b> | <b>Set all RPM1 configuration settings to their factory default values.</b>  |
| Valid range    | None   |
| <b>RESET</b>   | <b>Exit the modem and force a software reset.</b>  |
| Valid range    | Any changed parameters will take effect after the modem has restarted.<br>When exiting the configurator, the <i>HOST</i> device must ensure the <i>SETUP</i> pin is high otherwise the configurator will be re-entered after the reset.<br>None  |
| <b>UNIT</b>    | <b>Sets the unit number.</b>   |
| default        | Two RPM1 modules can communicate with each other provided they have matching<br>Unit numbers and Site codes.<br>0  |
| Valid range    | 0 to 15  |
| <b>SITE</b>    | <b>Sets the Site address</b>   |
| default        | The site number is used to distinguish between groups of operating modems. The<br>site code is an address extension to the unit number.<br>0   |
| valid range    | 0 to 7   |
| <b>ADDR</b>    | <b>Updates the unit number value.</b>  |
| default        | This command is used for changing the unit number in RAM without updating the<br>unit number stored in EEPROM. This enables the <i>RPM1</i> to support point-to-<br>multipoint communications.<br>0  |
| Valid range    | Upon using this command the configurator is exited and the modem operation is<br>resumed. The modem is not reset when the configurator is exited.<br>0 to 15   |
| <b>BAUD</b>    | <b>Sets the host interface baud rate.</b>  |
| default        | The changed baud rate will take effect after resetting the RPM1.<br>9600   |
| valid range    | 600, 1200, 2400, 4800, 9600, 19200, 38400, 57600, 115200   |
| <b>THRUPUT</b> | <b>Sets the on-air data throughput.</b>  |
| default        | Three possible settings are provided.<br><b>max</b> : sets the maximum data throughput of the RPM1.  |
| valid range    | <b>slots</b> : effectively reduces the on-air throughput. This opens up 'time slots'<br>allowing other RPM1 pairs, operating within close proximity, equal<br>opportunity to transmit data.<br><b>slotsw</b> : increases the 'time slots' even further to allow more RPM1 pairs to<br>operate.<br>max, slots, slotsw |

|                |  |
|----------------|--|
| <b>FLOW</b>    | <p><b>Sets the serial flow control between the host and RPM1.</b></p> <p>Using no flow control enables the RPM1 to be used with a 3 wire serial link (TXD, RXD, GND). Care must be taken in order to prevent overflowing the 96 byte serial receive buffer in the RPM1.</p> <p>Using hardware flow control enables the RPM1 to control the flow of serial data being received.</p> <p>default none<br/>valid range hw, none</p>  |
| <b>SERDLY</b>  | <p><b>Sets the serial data receive to packet transmit delay.</b></p> <p>When the RPM1 receives the first byte of data from the host, it starts a timer running. Either a full buffer of data to send or a timeout of this timer will allow the packet to be transmitted.</p> <p>Fine tuning this delay for the baud rate the RPM1 is operating at can significantly increase throughput while reducing unnecessary transmissions.</p> <p>default 2 (x10ms)<br/>valid range 2 to 255 (x10ms)</p>  |
| <b>SHDN</b>    | <p><b>Sets the action of the WAKE input.</b></p> <p>Setting shutdown to <i>ON</i> will cause the RPM1 to monitor the <i>WAKE</i> input. When <i>WAKE</i> is taken high the RPM1 will be forced into low power sleep mode, thus reducing current consumption. Subsequently lowering the <i>WAKE</i> input will bring the RPM1 out of low power sleep mode.</p> <p>SHDN should be set to <i>OFF</i> or <i>WAKE</i> pin should be pulled Low when the host (DTE) cannot provide DTR control signal to wake RPM1 in a 3-wire serial interface. Do not set it to <i>OFF</i> for RPM1 Issue 2.</p> <p>default On<br/>valid range on, off</p> |
| <b>RETRY</b>   | <p><b>Sets the number of data retry attempts.</b></p> <p>RF interference can cause a transmitted data packet to be lost or corrupt on reception. If this happens the RPM1 will retransmit any unacknowledged transfer. The transmission will be retried the specified number of times before the link to the remote unit is considered 'lost' and the data purged.</p> <p>default 5<br/>valid range 1 to 63</p>  |
| <b>STRMSG</b>  | <p><b>Enables the startup message.</b></p> <p>The startup message is enabled by default, thus giving an immediate indication of the operation of the RPM1. The message can be disabled prior to deployment of the RPM1 module.</p> <p>default On<br/>valid range on, off</p>   |
| <b>ACKMODE</b> | <p><b>Enables transfer acknowledgements.</b></p> <p>This function enables packet transfer acknowledgements to be returned for every outgoing packet. Packet acknowledgements aid in the delivery of error free and consistent data transfers between a pair of modems. Disabling the acknowledgements results in higher data throughput between modems, but does not protect against lost data due to RF interference. It should be disabled while using RPM1 in a broadcast mode. Do not set it to <i>ON</i> for RPM1T and RPM1R as they cannot establish connection.</p> <p>default On<br/>valid range on, off</p>                   |
| <b>REMOTE</b>  | <p><b>Enables remote configuration.</b></p> <p>Over-air remote configuration of a RPM1 module is possible once it has been enabled. The remote command is used to send remote configuration commands. See the following chapter for an overview of remotely configuring a RPM1 module.</p> <p>default Off<br/>valid range on, off</p>  |
| <b>RADAR</b>   | <p><b>Starts the radar test.</b></p> <p>Used as a range or confidence test between RPM1 modules within the same <i>site</i>.</p>   |

parameter            Unit number between 0 and 15.

To configure the RPM1 the HyperTerminal should be set with the following settings.

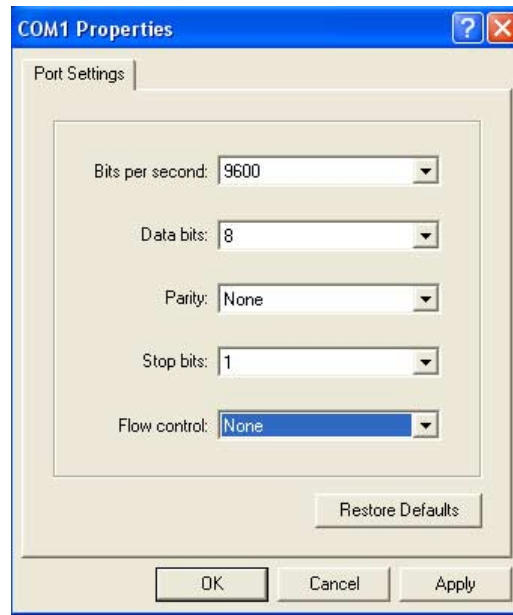

**Figure 6: Serial Port settings to use RPM1 Configurator**

Hardware flow control should be disabled. Default baud rate of the RPM1 is 9600bps. However if the default baud rate of the RPM1 is changed then the baud rate of the HyperTerminal should be matched or DEFAULT pin should be pulled Low force the RPM1 baud rate to 9600bps.

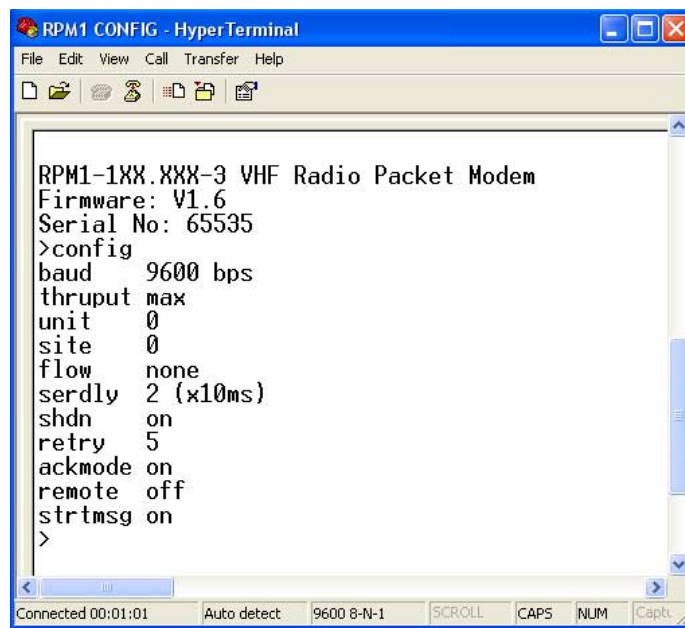

**Figure 7: RPM1 configuration using HyperTerminal**

User configurable parameters described in section 3.2 should be entered in the command prompt > followed by Carriage Return (CR) key. Then SETUP should be pulled-up to VCC and RPM1 should be RESET to exit the configurator and for the new parameters to be used by RPM1.

## 4.0 EXTENDED RADIO PACKET MODEM FEATURES

### 4.1 THROUGHPUT

The RPM1 supports three rates, max (3.6kbps), slots (1.2kbps) and slotsw (600bps), of over-air throughput.

**MAX:** When set to maximum and streaming data at the RPM1, the data is sent as quick as possible. For host baud rates of 4800bps and above, data is transmitted continuously with minimal delay between sequential packets. When this occurs, there is effectively no airtime for another pair, operating in close proximity, to transmit without causing collisions. The maximum over-air throughput that can be achieved is 3.6kbps with ACK and 5.4kbps without ACK.

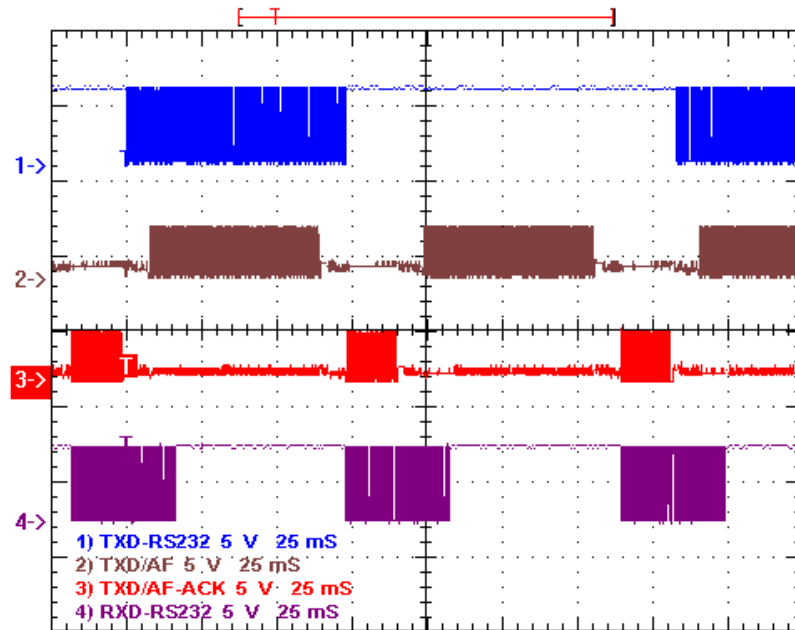

Figure 8: RPM1 pair streaming data without gap for another RPM1 pair

In Figure 8, RS232 serial data bytes accumulated in the receive buffer is transmitted as two 10kbps bursts by transmitting RPM1 with gaps just enough to receive ACK from receiving RPM1.

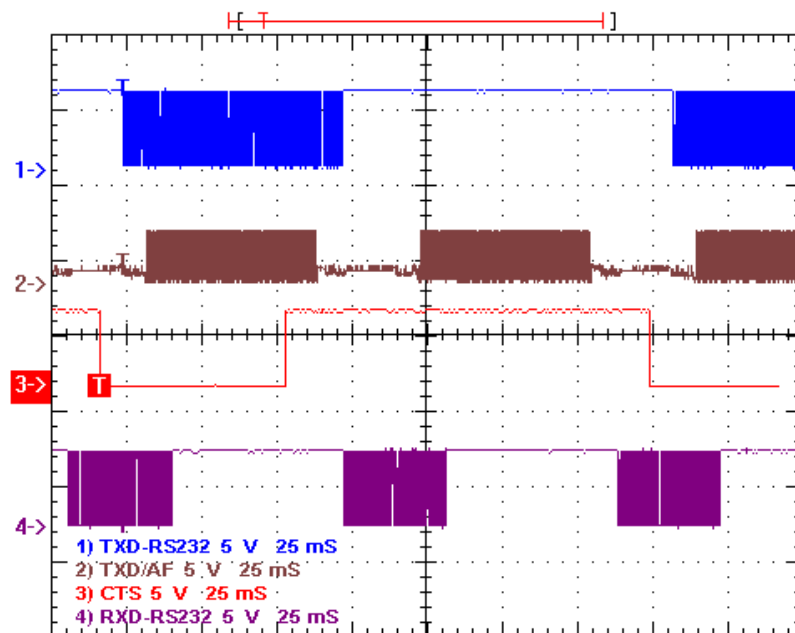
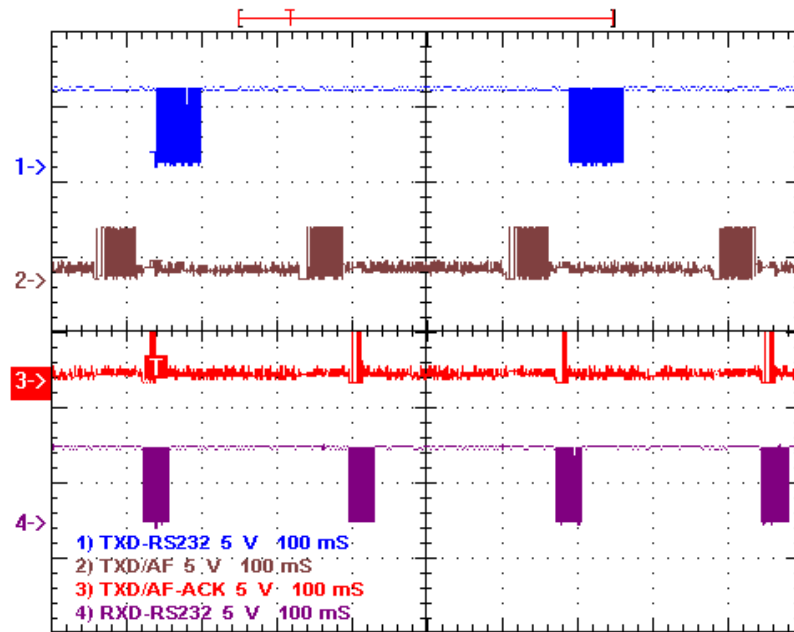

FIGURE 9: RPM1 pair streaming 9600bps serial data with ACK at maximum throughput

For continuous data transmission at baud rates above 2400bps (with ACK) or 4800bps (without ACK), hardware flow control should be used to prevent the host from causing receive buffer overrun errors. RPM1 will signal CTS pin to stop/allow the host depending on its Receiver Buffer level.

**SLOTS:** Setting the throughput to *SLOTS* provides a method of opening 'time slot' for other RPM1 pairs operating in close proximity. The effective streaming on-air throughput between a pair of RPM1 is effectively reduced to approximately 1200bps (with/without ACK).



**Figure 10: RPM1 operating in slots throughput mode**

**SLOTSW:** This setting effectively widens the *SLOTS*, reducing the over-air throughput to approximately 600bps (with/without ACK). It allows more RPM1 pairs to share the same frequency. Host should obey CTS flow control signal from RPM1 when using *SLOTS* or *SLOTSW* mode.

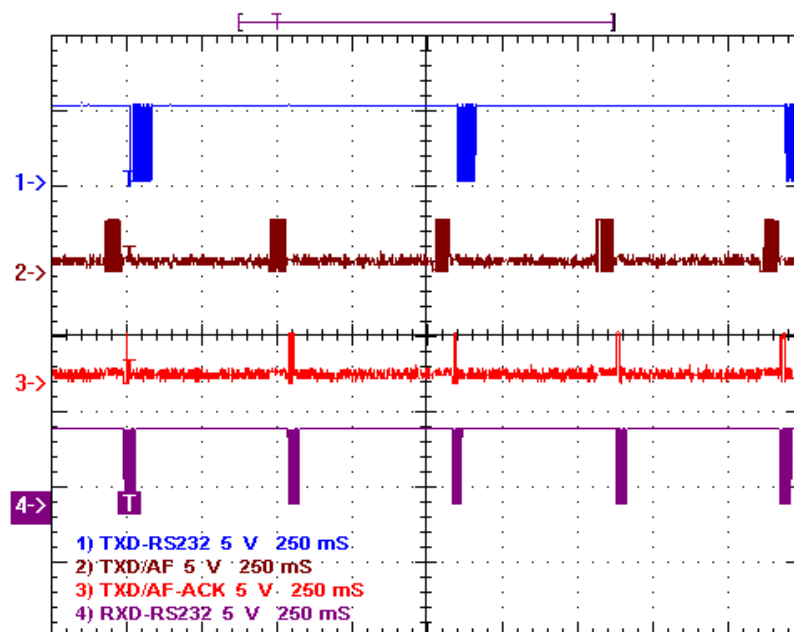

**Figure 11: RPM1 operating in slotsw throughput mode**

Certain fast file transfer protocols like ZMODEM are not suitable for *SLOTSW* mode. KERMIT or similar protocol which tolerates wider time gaps between packets should be used in this mode.

## 4.2 Remote Configuration

Remote configuration of a RPM1 module is possible using the *REMOTE* command from within the configurator. The remote RPM1 unit should be on or in auto-standby mode.

Initially the *REMOTE* command is used to enable and disable the ability to remotely configure a module, as described in section 3.2: User Configurable Command.

Once remote configuration is enabled the *REMOTE* command is then used to issue configuration commands to a remote RPM1. The format for the remote command then becomes:

```
REMOTE <SERIAL NUM> <COMMAND> <PARAMTER>
```

The <SERIAL NUMBER> of the remote RPM1 must be known in order for the remote configuration request to be executed on the appropriate RPM1 module.

The <COMMAND> to be executed can be any of the following:

- Baud 600,1200,2400,4800,9600,19200,38400,57600,115200
- Unit 0 to 15
- Site 0 to 7
- Shdn on/off
- Flow hw/none
- Serdly 2 to 255
- Retry 1 to 63
- Strtmsg on/off

The <PARAMETER> is optional, and if not specified the setting for that command is returned and displayed.

## 4.3 POINT-TO-MULTIPOINT

The *RPM1* can be used for point-to-multipoint communications. One module must be considered to be the master, which is used to address up to 15 remote units in any one site.

During normal operation, the base unit can be set to address another unit dynamically by entering the configurator and using the *ADDR* command to change the unit address. Upon execution of this command, provided the parameters are correct, the configurator is exited immediately. A period ('.') is sent to the connected host device to indicate that the change has been registered and the RPM1 is now ready for communications to the new unit address.

*ADDR* is very similar to the *Unit* command, except that *ADDR* does not update the stored EEPROM unit value. As the EEPROM has a limited number of write cycles, using *ADDR* for addressing multiple units in a point to multipoint network is recommended. Also, the *ADDR* command will exit the configurator immediately, which is required to resume communications very quickly.

## 4.4 BROADCAST MULTIDROP

The RPM1 has a broadcast mutidrop mode which provides a mechanism for building a large networks. This mode of operation is determined by the configuration command keyword ***ACKMODE*** being set to ***OFF***.

In broadcast mutidrop mode, the RPM1 does not implement network layer functionality related to data packet routing, acknowledgement and retries. The connected host device should provide network layer functionality.

The site code and unit address is still used by the radio modem when working in broadcast multidrop mode. For a given multipoint network all radio modems within a group must contain the same site code and unit address.

#### 4.5 RADAR: DIAGNOSTIC TEST

Built into the configurator is a diagnostic test suitable for range testing and link confidence testing. The Radar test effectively sends a small request packet to a remote unit then waits for a reply. The remote unit must not be in the configurator otherwise it will not respond.

Upon receipt of a positive response from the remote unit, a success is recorded before the process is repeated. This test will continue indefinitely until it is ended by a key press.

#### 4.6 Radio Packet Modem Error Handling

The RPM1's radio decoder module is deliberately non bit error tolerant, i.e. no attempt is made to repair corrupt data bits. All of the redundancy in the code is directed towards error checking. For an FM radio link using short packet lengths, packets are either 100% or so grossly corrupt as to be unrecoverable. By the same reasoning, the Host is not informed or sent corrupt data since corrupt information is of little value. The RPM1 implements packet acknowledges, timeouts and re-transmission to accomplish reliable error handling.

### **Ordering information**

RPM1 issue 2 will be supplied as default.

| <b>Part number</b>   | <b>RF output</b> | <b>Supply</b> |
|----------------------|------------------|---------------|
| RPM1-151.300-3       | 100mW            | 5V            |
| RPM1-173.225-3       | 10mW             | 5V            |
| RPM1-173.250-3       | 10mW             | 5V            |
| RPM1-151.300-3-LP    | 10mW             | 5V            |
| RPM1-151.300-3-LP-3V | 10mW             | 3.3V          |
| RPM1-173.225-3-HP    | 100mW            | 5V            |
| RPM1-173.250-3-HP    | 100mW            | 5V            |
| RPM1-173.225-3-3V    | 10mW             | 3.3V          |
| RPM1-173.250-3-3V    | 10mW             | 3.3V          |

Above RPM1 transceiver can also be ordered as separate RPM1T transmitter and RPM1R receiver.

# Appendix A

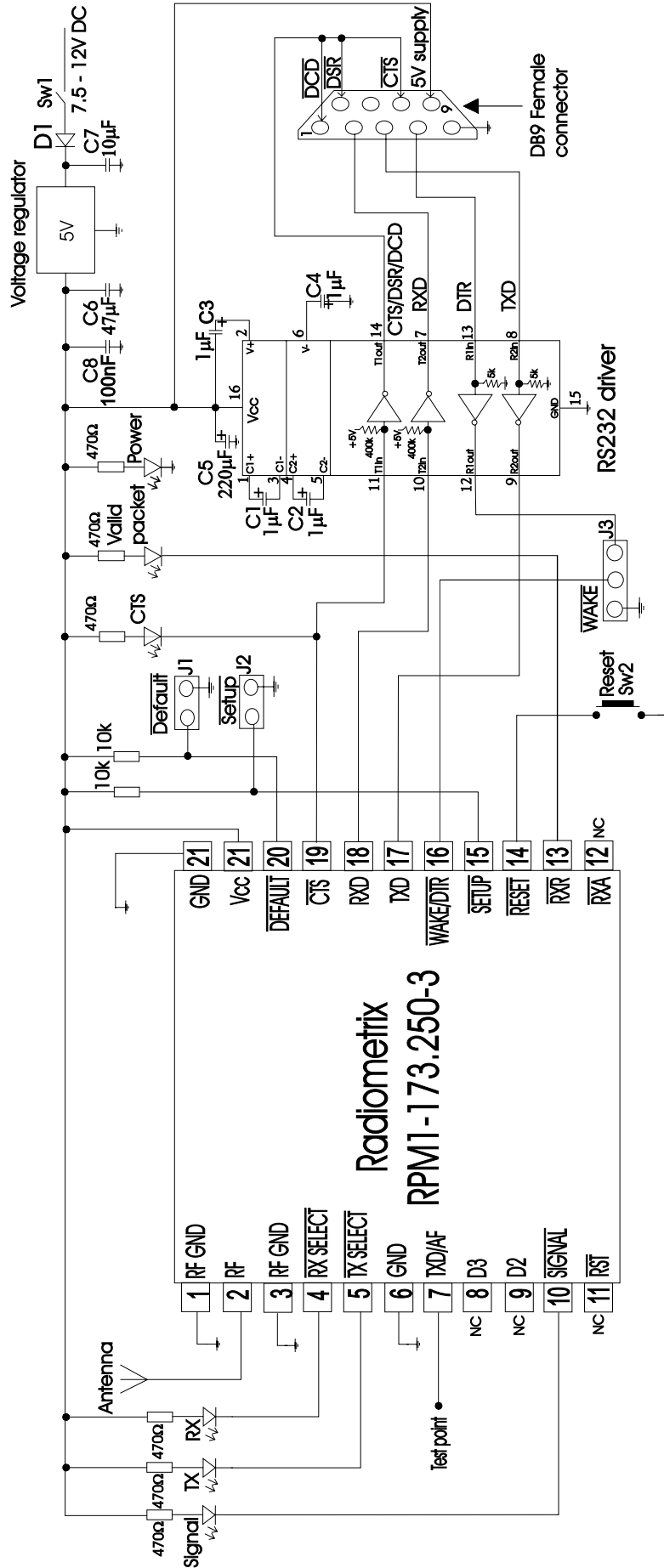

Figure 7: Example circuit to make radio modem with DCE type RS232 interface

# **Radiometrix Ltd**

**Hartcran House  
231 Kenton Lane  
Harrow, Middlesex  
HA3 8RP  
ENGLAND  
Tel: +44 (0) 20 8909 9595  
Fax: +44 (0) 20 8909 2233  
sales@radiometrix.com  
www.radiometrix.com**

## **Copyright notice**

*This product data sheet is the original work and copyrighted property of Radiometrix Ltd. Reproduction in whole or in part must give clear acknowledgement to the copyright owner.*

## **Limitation of liability**

*The information furnished by Radiometrix Ltd is believed to be accurate and reliable. Radiometrix Ltd reserves the right to make changes or improvements in the design, specification or manufacture of its subassembly products without notice. Radiometrix Ltd does not assume any liability arising from the application or use of any product or circuit described herein, nor for any infringements of patents or other rights of third parties which may result from the use of its products. This data sheet neither states nor implies warranty of any kind, including fitness for any particular application. These radio devices may be subject to radio interference and may not function as intended if interference is present. We do NOT recommend their use for life critical applications. The Intrastat commodity code for all our modules is: 8542 6000.*

## **R&TTE Directive**

*After 7 April 2001 the manufacturer can only place finished product on the market under the provisions of the R&TTE Directive. Equipment within the scope of the R&TTE Directive may demonstrate compliance to the essential requirements specified in Article 3 of the Directive, as appropriate to the particular equipment.*

*Further details are available on The Office of Communications (Ofcom) web site:*

***[http://www.ofcom.org.uk/radiocomms/ifi/licensing/licensing\\_policy\\_manual/](http://www.ofcom.org.uk/radiocomms/ifi/licensing/licensing_policy_manual/)***

### *Information Requests*

*Ofcom  
Riverside House  
2a Southwark Bridge Road  
London SE1 9HA  
Tel: +44 (0)845 456 3000 or 020 7981 3040  
Fax: +44 (0)20 7783 4033  
information.requests@ofcom.org.uk*

### *European Radiocommunications Office (ERO)*

*Peblingehus  
Nansensgade 19  
DK 1366 Copenhagen  
Tel. +45 33896300  
Fax +45 33896330  
ero@ero.dk  
www.ero.dk*

---